

features

- Wide lineup from 01005 to 2512 size
- Excellent heat resistance and weather resistance, because of the use of glaze thick film as resistive film
- Suitable for both flow and reflow solderings
- Products with lead-free terminations meet EU RoHS requirements. EU RoHS regulation is not intended for Pb-glass contained in electrode, resistor element and glass.
- AEC-Q200 Qualified: 0201(1H), 0402(1E), 0603(1J), 0805(2A), 1206(2B), 1210(2E), 2010(2H/W2H), 2512(3A/W3A)

dimensions and construction

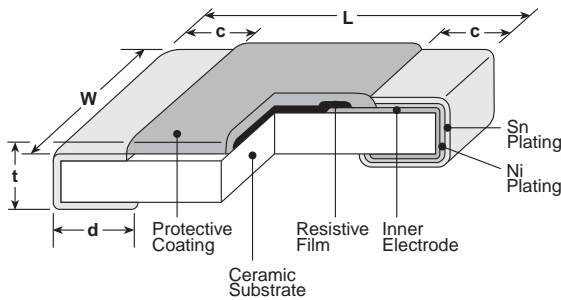

Derating Curve

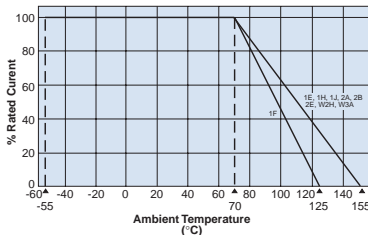

For resistors operated at an ambient temperature of 70°C or above, a current rating shall be derated in accordance with the above derating curve.

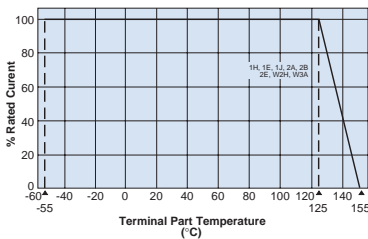

For resistors operated at a terminal part temperature of described for each size or above, a power rating shall be derated in accordance with the derating curve.

Please refer to "Introduction of the derating curve based on the terminal part temperature" in the beginning of our catalog before use.

Type (Inch Size Code)	Dimensions inches (mm)				
	L	W	c	d	t
1F (01005)	.016±.0008 (0.4±0.02)	.008±.0008 (0.2±0.02)	.004±.001 (0.10±0.03)	.004±.001 (0.11±0.03)	.005±.0008 (0.13±0.02)
1H (0201)	.024±.001 (0.6±0.03)	.012±.001 (0.3±0.03)	.004±.002 (0.1±0.05)	.006±.002 (0.15±0.05)	.009±.001 (0.23±0.03)
1E (0402)	.039 ^{+0.004} _{-.002} (1.0 ^{+0.1} _{-.05})	.02±.002 (0.5±0.05)	.008±.004 (0.2±0.1)	.01 ^{+0.002} _{-.004} (0.25 ^{+0.05} _{-.01})	.014±.002 (0.35±0.05)
1E AT (0402)			.01±.004 (0.25±0.1)	.012±.006 (0.3±0.15)	
1J (0603)	.063±.008 (1.6±0.2)	.031±.004 (0.8±0.1)	.012±.004 (0.3±0.1)	.012±.004 (0.3±0.1)	.018±.004 (0.45±0.1)
1J AT (0603)			.014±.006 (0.35±0.15)	.02±.008 (0.5±0.2)	
2A (0805)	.079±.008 (2.0±0.2)	.049±.004 (1.25±0.1)	.016±.008 (0.4±0.2)	.012 ^{+0.008} _{-.004} (0.3 ^{+0.2} _{-.01})	.02±.004 (0.5±0.1)
2A AT (0805)			.018±.010 (0.45±0.25)	.024±.008 (0.6±0.2)	
2B (1206)	.126±.008 (3.2±0.2)	.063±.008 (1.6±0.2)	.02±.012 (0.5±0.3)	.016 ^{+0.008} _{-.004} (0.4 ^{+0.2} _{-.01})	.024±.004 (0.6±0.1)
2B AT (1206)			.022±.014 (0.55±0.35)	.031±.008 (0.8±0.2)	
2E (1210)	.102±.008 (2.6±0.2)	.098±.008 (2.5±0.2)	.02±.012 (0.5±0.3)	.016 ^{+0.008} _{-.004} (0.4 ^{+0.2} _{-.01})	
2H (2010)	.197±.008 (5.0±0.2)			.026±.006 (0.65±0.15)	
W2H ¹ (2010)		.248±.008 (6.3±0.2)	.122±.008 (3.1±0.2)	.016 ^{+0.008} _{-.004} (0.4 ^{+0.2} _{-.01})	
3A (2512)	.026±.006 (0.65±0.15)				
W3A ¹ (2512)					

¹ RK73Z 2H and RK73Z 3A are also still available (different "d" dimensions = 0.4 +0.2/-0.1mm)

ordering information

RK73Z	2B		T	TD
Type	Size	Characteristics	Termination Material	Packaging
	1F 2E 1H W2H 1E W3A 1J 2H 2A 3A 2B	Nil: Standard A: Heat shock resistance ^{*2}	T: Sn G: Au ^{*3} (L:Sn/Pb ^{*4})	TX: 4mm width - 1mm pitch plastic embossed TBL - TCM: 2mm pitch press paper ^{*5} TPL - TP: 2mm pitch punch paper TD: 4mm pitch punch paper TE: 4mm pitch plastic embossed Other non-standard reel sizes available, contact factory for other options

^{*2} With type A only T is available as the terminal surface material.

^{*3} Products with gold plated electrodes are also available with 1E, 1J and 2A types (10Ω~1MΩ), so please consult with us.

^{*4} With type 1F, 1H, W2H, W3A, W3A2 only T is available as the terminal surface material.

For further information on packaging, please refer to Appendix A

^{*5} Standard taping specification of 1H is TCM. Previously available "TC (10,000pcs/Reel)" is not recommended for new designs

applications and ratings

Part Designation	Rated Ambient Temperature	Rated Terminal Part Temperature	Maximum Continuous Current @ 70°C	Maximum Overload Current @ 70°C (for < 1 second)	Maximum Resistance	Operating Temperature Range
RK73Z1F	70°C	—	0.5 Amps	1.0 Amp Max.	50mΩ	-55°C to +125°C
RK73Z1H		125°C	0.5 Amps	1.0 Amp Max.		-55°C to +155°C
RK73Z1E RK73Z1J			1.0 Amps	2 Amp Max.		
RK73Z2A			2.0 Amps	5 Amp Max.		
RK73Z2B RK73Z2E RK73Z2H/W2H RK73Z3A/W3A			2.0 Amps	10 Amp Max.		

environmental applications

One-Pulse Limiting Electric Power

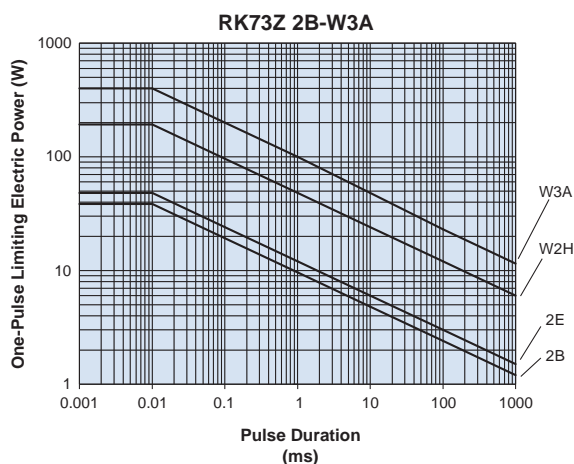
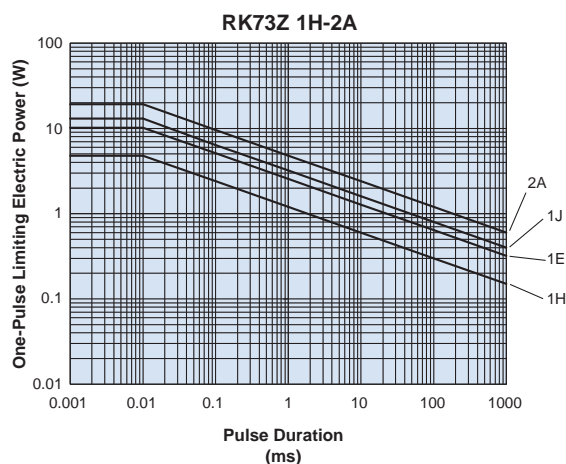

Please ask us about the resistance characteristic of continuous applied pulse.
 Please calculate One-Pulse Limiting Electric Power using upper limit of resistance (50mΩ or 100mΩ) for applied current.
 The pulse endurance values are not assured values, so be sure to check the products on actual equipment when you use them.

Performance Characteristics

Parameter	Requirement		Test Method
	Limit	Typical	
Resistance	50mΩ Max. after the test	15mΩ Max. after the test	25°C
Overload (Short time)	50mΩ Max. after the test	18mΩ Max. after the test	Maximum overload current for 5 seconds , 1 cycle
Resistance to Solder Heat	50mΩ Max. after the test	15mΩ Max. after the test	260°C ± 5°C, 10 seconds ± 1 second
Rapid Change of Temperature	50mΩ Max. after the test	15mΩ Max. after the test	Characteristic (Nil) Standard: -55°C (30 minutes), +125°C (30 minutes), 100 cycles Characteristic (A) Heat Shock Resistance: -55°C (30 minutes), +125°C (30 minutes), 1000 cycles
Moisture Resistance	100mΩ Max. after the test	18mΩ Max. after the test	40°C ± 2°C, 90%-95% RH, 1000 hours, 1.5 hr ON, 0.5 hr OFF cycle
Endurance at 70°C	100mΩ Max. after the test	18mΩ Max. after the test	70°C ± 2°C, 1000 hours, 1.5 hr ON, 0.5 hr OFF cycle
High Temperature Exposure	100mΩ Max. after the test	15mΩ Max. after the test	+125°C, 1000 hours: 1F +155°C, 1000 hours: 1H, 1E, 1J, 2A, 2B, 2E, W2H/2H, W3A/3A

Specifications given herein may be changed at any time without prior notice. Please confirm technical specifications before you order and/or use.

4/26/22